

**GENERAL NOTES :**

- 1) THE ANCHORAGE METHODS SHOWN HAVE BEEN DESIGNED TO COMPLY WITH THE FLORIDA BUILDING CODE FOR THE DESIGN PRESSURES LISTED.
- 2) WOOD BUCKS DEPICTED AS 1X ARE LESS THAN 1-1/2" THICK. 1X WOOD BUCKS ARE OPTIONAL IF UNIT IS INSTALLED DIRECTLY TO SOLID CONCRETE. WOOD BUCKS DEPICTED AS 2X ARE 1-1/2" THICK OR GREATER. ATTACHMENT METHOD OF WOOD BUCKS SHALL BE DONE BY OTHERS.
- 3) SEE TABLE FOR MINIMUM EDGE DISTANCE FROM CENTER OF ANCHOR TO SUBSTRATE EDGE (EXCLUDING FINISH OR STUCCO).
- 4) SHIM EACH ANCHOR LOCATION WHERE THE PRODUCT IS NOT FLUSH TO THE SUBSTRATE, USING SHIMS CAPABLE OF TRANSFERRING APPLIED LOADS.
- 5) ANCHORS SHALL BE COATED OR CORROSION RESISTANT AS APPROPRIATE FOR SUBSTRATE MATERIAL. DISSIMILAR MATERIALS SHALL BE PROTECTED AS REQUIRED TO PREVENT REACTIONS. ALUMINUM SHALL BE PROTECTED FROM DISSIMILAR MATERIALS AS SPECIFIED IN FLORIDA BUILDING CODE CHAPTER 20.
- 6) ADHESIVE SEALANT SHALL BE USED BETWEEN SUBSTRATE AND FLANGE OR FIN. OVERALL SEALING/FLASHING STRATEGY FOR WATER RESISTANCE OF INSTALLATION SHALL BE DONE BY OTHERS.
- 7) MATERIALS USED FOR ANCHOR EVALUATIONS WERE SOUTHERN PINE, 2.7 KSI CONCRETE AND CONCRETE MASONRY UNITS COMPLYING WITH ASTM C-90. GLAZING COMPLIES WITH ASTM E1300-04.
- 8) THE 1/3 STRESS INCREASE WAS NOT USED IN THIS ANCHOR EVALUATION. THE 1.6 LOAD DURATION FACTOR WAS USED FOR THE EVALUATION OF WOOD SCREWS.
- 9) IF THE EXACT PRODUCT SIZE IS NOT LISTED IN THE TABLES, ALWAYS ROUND UP TO THE NEXT LARGER VALUE.

**IMPACT RESISTANT**

**ANCHOR LOCATIONS & SPACING**

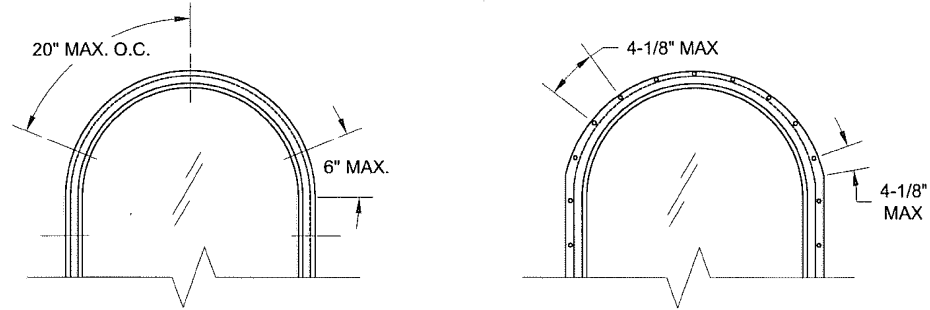

ADD 1 ANCHOR AT MID-SPAN FOR WW > 32"

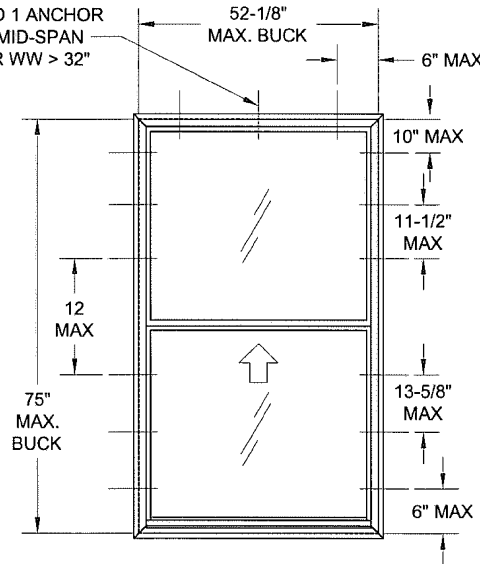

**FLANGE & EQUAL LEG FRAME**  
SEE GLAZING DETAIL, SHEET 4

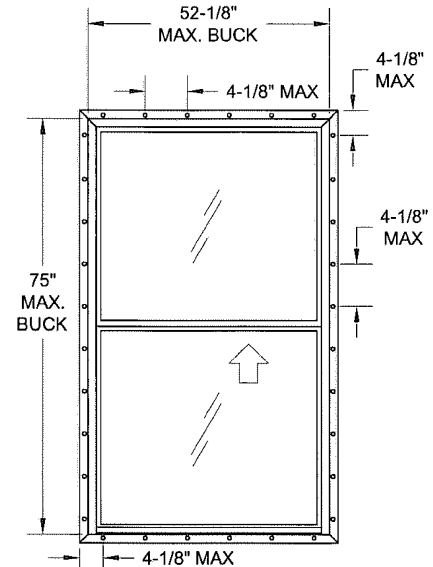

**FIN FRAME**  
SEE GLAZING DETAIL, SHEET 4

**TABLE 1: FIN & FLANGE WINDOWS**

Buck Size		Design Pressure		Certification	Test Reports
Width	Height	(+) psf	(-) psf	Numbers	
52-1/8"	75"	60	70	190-231, 477	FTL - 5711, 5725

**TABLE 2: FLANGE WINDOWS**

Anchor Type	Substrate	Min. Edge Dist.	Min. Embedment
#10 Steel SMS	Wood (Southern Pine)	7/16"	1-3/8"
	Steel Stud Gr 33	3/8"	.045 (18 GA)
	Aluminum-6063-T5	3/8"	1/8"
	Steel, A36	3/8"	1/8"
3/16" Masonry Anchor	Concrete	1"	1-3/8"
	Hollow CMU	2-1/2"	1-1/4"

NOTE: FOR ALL METAL SUBSTRATES, SCREW EMBEDMENT SHALL BE MIN. 3 THREADS BEYOND INSIDE FACE OF MATERIAL.

**TABLE 3: FIN WINDOWS**

Anchor Type	Substrate	Min. Edge Dist.	Min. Embedment
1-1/2" x .135" Roofing Nail	Wood (Southern Pine)	3/8"	1-7/16"
2-1/2" x .131" Common Nail	Wood (Southern Pine)	3/8"	2-7/16"
#12 Panhead SMS	Wood (Southern Pine)	9/16"	1-3/8"
#10 Trusshead Screw	Wood (Southern Pine)	7/16"	1-3/8"

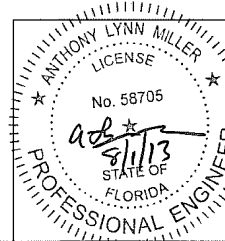

**PGI**  
1070 TECHNOLOGY DRIVE  
NOKOMIS, FL 34275  
FL CERT. OF AUTH. : 29296  
A. Lynn Miller, P.E.  
P.E. #58705

Drawn By: J. ROSOWSKI	Date: 08/01/13	Material: RIGID VINYL	THE INFORMATION, DESIGN OR DATA CONTAINED HEREIN IS THE EXCLUSIVE PROPERTY OF PGT INDUSTRIES AND CONSIDERED CONFIDENTIAL AND PROPRIETARY. NO PORTION OF THIS DOCUMENT MAY BE USED OR REPRODUCED IN ANY FORM WITHOUT THE EXPRESSED WRITTEN PERMISSION OF PGT INDUSTRIES.
Revised By:	Date:	Revisions:	
Description:			
Title: <b>SINGLE HUNG INSTALLATION</b>			
Series/Model: SH-500	Scale: NTS	Sheet: 1 of 4	Drawing No. 2032511JR
Rev:			

**INSTALLATION WITH FLANGE FRAME  
(FIN REMOVED)**

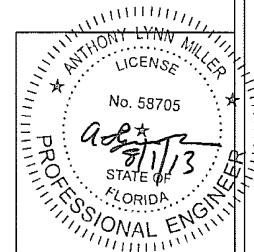
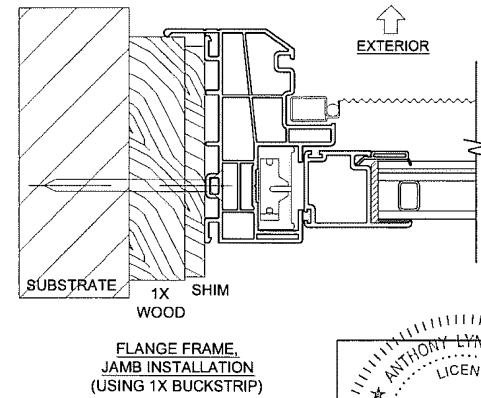
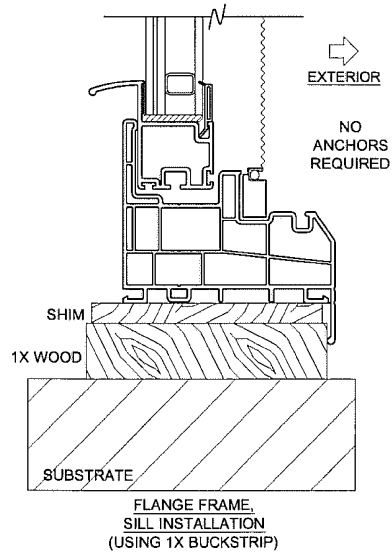
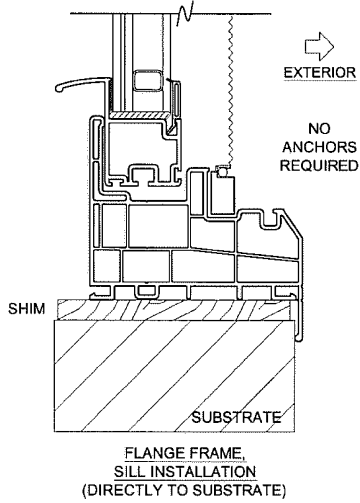
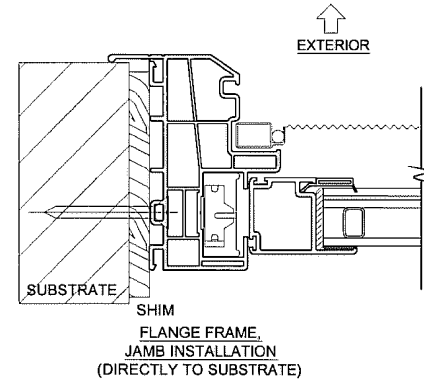
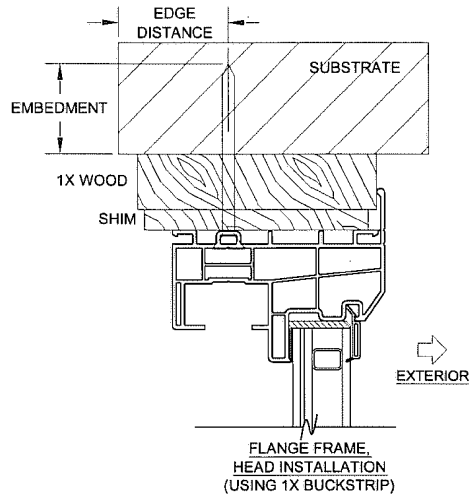
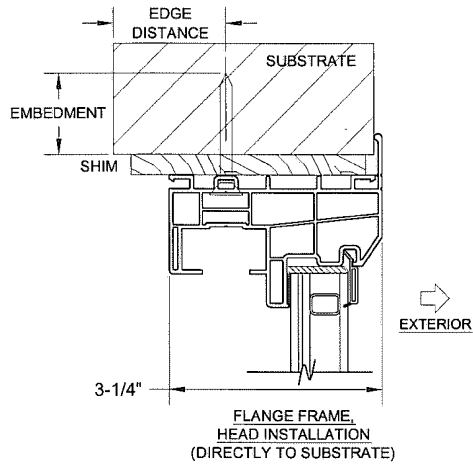

**INSTALLATION NOTES:**

- 1) SEE SHEET 1 FOR SPACING REQUIREMENTS.
- 2) SEE TABLE 2 FOR ANCHORAGE AND SUBSTRATE REQUIREMENTS.
- 3) MAX. SHIM THICKNESS TO BE 1/4".
- 4) ANCHORS HEAD TYPE MAY DIFFER FROM SHOWN.

 1070 TECHNOLOGY DRIVE NOKOMIS, FL 34275 FL CERT. OF AUTH. : 29296	Drawn By:	Date:	Material:	THE INFORMATION, DESIGN OR DATA CONTAINED HEREIN IS THE EXCLUSIVE PROPERTY OF PGT INDUSTRIES AND CONSIDERED CONFIDENTIAL AND PROPRIETARY. NO PORTION OF THIS DOCUMENT MAY BE USED OR REPRODUCED IN ANY FORM WITHOUT THE EXPRESSED WRITTEN PERMISSION OF PGT INDUSTRIES.
	J. ROSOWSKI	08/01/13	RIGID VINYL	
	Revised By:	Date:	Revisions:	
Description:				
Title: <b>SINGLE HUNG INSTALLATION</b>				
A. Lynn Miller, P.E. P.E. #58705	Series/Model: SH-500	Scale: NTS	Sheet: 2 of 4	Drawing No. 2032511JR

**INSTALLATION WITH EQUAL LEG FRAME  
(FIN AND FLANGE REMOVED)**

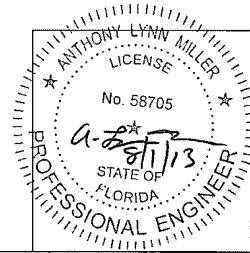
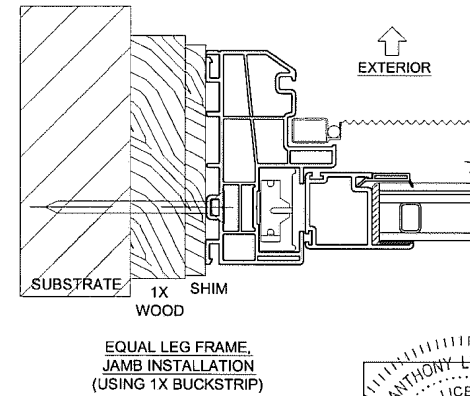
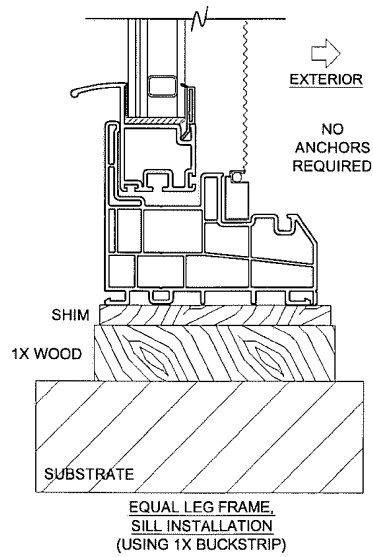
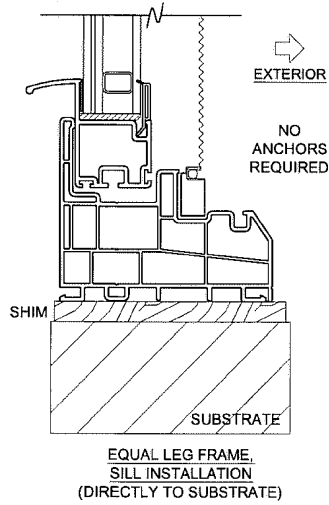
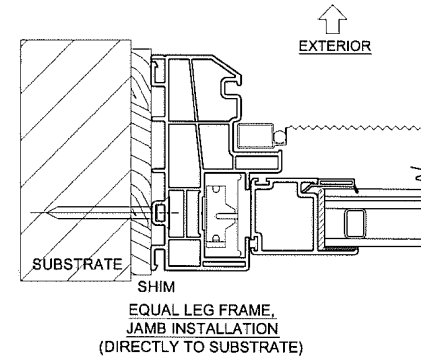
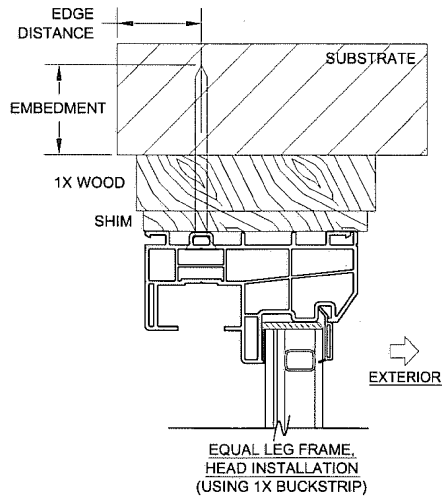
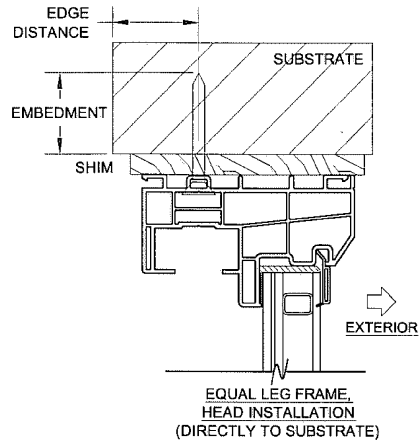

**INSTALLATION NOTES:**

- 1) SEE SHEET 1 FOR SPACING REQUIREMENTS.
- 2) SEE TABLE 2 FOR ANCHORAGE AND SUBSTRATE REQUIREMENTS.
- 3) MAX. SHIM THICKNESS TO BE 1/4".
- 4) ANCHORS HEAD TYPE MAY DIFFER FROM SHOWN.

	Drawn By: <b>J. ROSOWSKI</b>	Date: 08/01/13	Material: RIGID VINYL	THE INFORMATION, DESIGN OR DATA CONTAINED HEREIN IS THE EXCLUSIVE PROPERTY OF PGT INDUSTRIES AND CONSIDERED CONFIDENTIAL AND PROPRIETARY. NO PORTION OF THIS DOCUMENT MAY BE USED OR REPRODUCED IN ANY FORM WITHOUT THE EXPRESSED WRITTEN PERMISSION OF PGT INDUSTRIES.		
	Revised By:	Date:	Revisions:			
Description:				<b>SINGLE HUNG INSTALLATION</b>		
Title:						
1070 TECHNOLOGY DRIVE NOKOMIS, FL 34275 FL CERT. OF AUTH. : 29296 A. Lynn Miller, P.E. P.E. #58705		Series/Model: SH-500	Scale: NTS	Sheet: 3 of 4	Drawing No. 2032511JR	Rev:

INSTALLATION WITH FIN FRAME

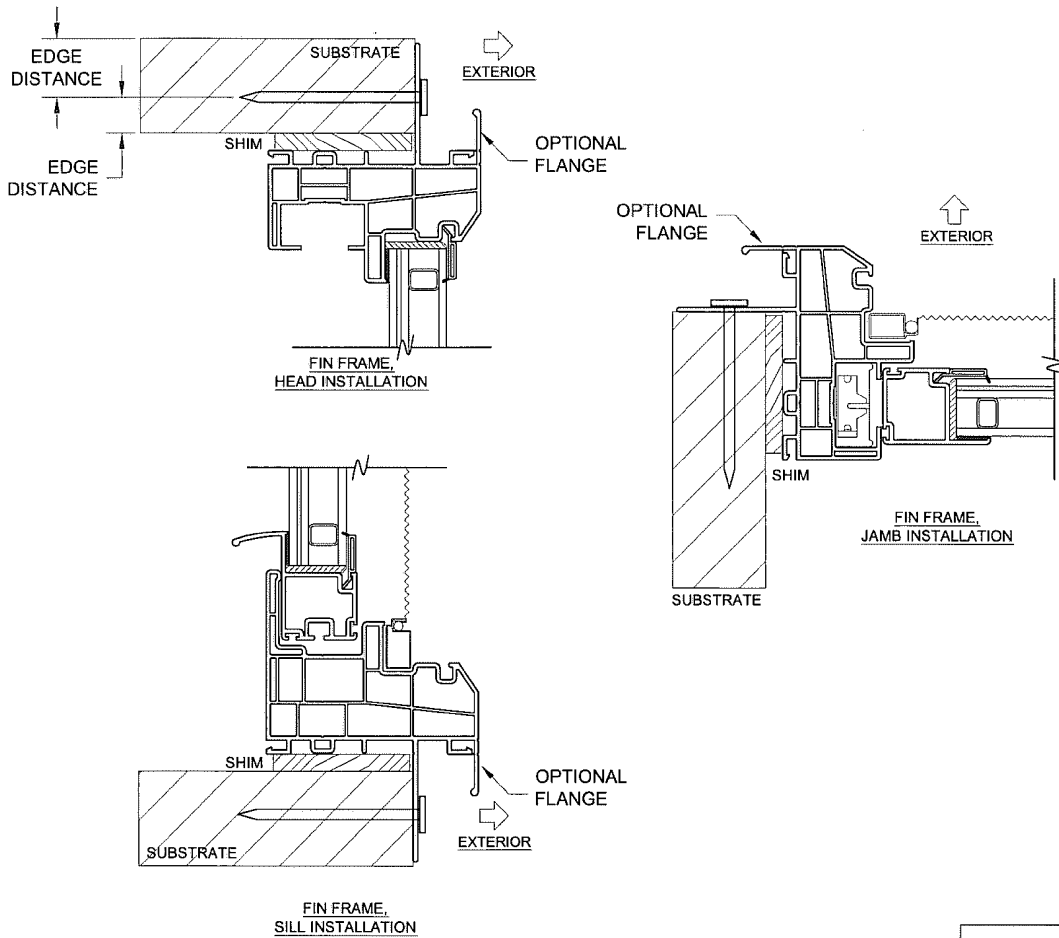

GLAZING DETAIL  
ALL FRAME TYPES

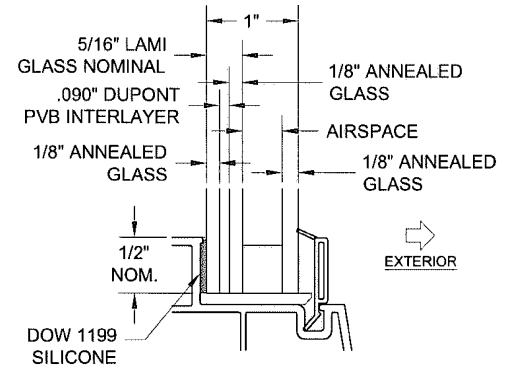

INSTALLATION NOTES:

- 1) SEE SHEET 1 FOR SPACING REQUIREMENTS.
- 2) SEE TABLE 3 FOR ANCHORAGE AND SUBSTRATE REQUIREMENTS.
- 3) MAX. SHIM THICKNESS TO BE 1/4".

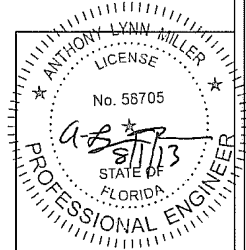

	Drawn By:	Date:	Material:	<small>THE INFORMATION, DESIGN OR DATA CONTAINED HEREIN IS THE EXCLUSIVE PROPERTY OF PGT INDUSTRIES AND CONSIDERED CONFIDENTIAL AND PROPRIETARY. NO PORTION OF THIS DOCUMENT MAY BE USED OR REPRODUCED IN ANY FORM WITHOUT THE EXPRESSED WRITTEN PERMISSION OF PGT INDUSTRIES.</small>
	J. ROSOWSKI	08/01/13	RIGID VINYL	
	Revised By:	Date:	Revisions:	
Description:				
Title: <b>SINGLE HUNG INSTALLATION</b>				
A. Lynn Miller, P.E. P.E. #58705	Series/Model: SH-500	Scale: NTS	Sheet: 4 of 4	Drawing No. 2032511JR